

INPADOCDB

(INternational PATent DOCumentation DataBase)

Subject Coverage	All areas of science and technology, i.e., all classes of the International Patent Classification				
File Type	Bibliographic				
Features	Thesauri	European Patent Classification (/EPC and /ICO), International Patent Classification (/IPC), US National Patent Classification (/NCL)			
	Alerts (SDIs)	Weekly or monthly (Weekly is the default)			
	CAS Registry Numbers [®]	<input type="checkbox"/>	Page Images	<input type="checkbox"/>	STN AnaVist <input type="checkbox"/>
	Keep & Share	<input checked="" type="checkbox"/>	SLART	<input checked="" type="checkbox"/>	STN Easy <input checked="" type="checkbox"/>
	Learning Database	<input checked="" type="checkbox"/>	Structures	<input type="checkbox"/>	STN Viewer <input type="checkbox"/>
Record Content	<ul style="list-style-type: none"> • Bibliographic and family data of patent documents and utility models of more than 90 patent-issuing organizations including the European Patent Office (EPO) and the World Intellectual Property Organization (WIPO) • Legal status data of 59 patent-issuing organizations (43 countries + from 16 countries of the national phases PCT/EP) • Over 30.8 million abstracts are available • First page images are available for the following patent authorities: CH (1978-), DE (1970-), EP (1978-), FR (1969-), GB (1969-), JP (1980-), US (1971-), and WO (1978-) • Note: The accession number can change due to corrections/updates of patent relevant numbers and codes 				
File Size	<p>More than 60 million records (applications) including national patent families with about 76 million publications; 39 million families (01/12) from 1790 to the present</p> <p>More than 89 million legal status data in almost 22 million records (01/12) from 1978 to the present</p> <p>More than 85 million patent and non-patent citations are available for 23 authorities from 1943 to the present</p>				
Coverage	1790-present				
Updates	Weekly with 70,000-100,000 records and 40,000-180,000 legal status data				
Language	English				
Database Producer	European Patent Office Vienna Sub Office P.O. Box 90 Austria Phone: +43 1 52126-0 Fax: +43 1 52126-5491 E-mail: inpadoc.help@epo.org Copyright Holder				

Database Supplier FIZ Karlsruhe
STN Europe
P.O. Box 2465
76012 Karlsruhe
Germany
Phone: +49 7247 808-555
Fax: +49 7247 808-259
E-mail: helpdesk@fiz-karlsruhe.de
Copyright Holder

- Sources**
- EPO-Patent Information Resource based on the data supplied by the patent offices (INPADOC/DOCDB Service)
 - INPADOC Legal Status Service
-

- User Aids**
- Online Helps (HELP DIRECTORY lists all help messages available)
 - STNGUIDE
 - ECLA (EPC, ICO) and IDT descriptions in pdf files – updated monthly (see file banner)
 - More information and additional links see on the INPADOCDB/INPAFAMDB web site
http://www.stn-international.de/details_inpadocdb.html
http://www.stn-international.de/inpadocdb_inpafamdb_handbook.html
-

- Clusters**
- ALLBIB
 - AUTHORS
 - CORPSOURCE
 - HPATENTS
 - PATENTS
- [STN Database Clusters](#) information (PDF)
-

Pricing See the [STN Price List](#) or enter HELP COST at an arrow prompt.

Search and Display Field Codes

Fields that allow left truncation are indicated by an asterisk (*).

Bibliographic Search Fields

Search Field Name	Search Code	Search Examples	Display Codes
Basic Index* (contains single words from title (TI) and abstract (AB) fields)	None or /BI	S TUBULAR HEAT EXCHANG? S ALUM? (S) COAT? S ?MAGNET? S ?METHYL?(T)?AMINO?	AB, ABDE, ABFR, ABES, ABOL, TI
Abstract* (contains AB, ABDE, ABES, ABFR, ABOL) (1)	/AB	S (DRILLING(W)PROCESS)/AB	AB, ABDE, ABES, ABFR, ABOL
Abstract Language (ISO code and text)	/AL	S DUTCH/AL	ALL, ALLO, IMAX, MAX, MAXO
Accession Number	/AN	S 12345678/AN	AN
Application Country (WIPO code and text)	/AC	S WO/AC AND (INLAND(W)STEEL)/PA	AI
Application Date (2)	/AD	S 19840705/AD	AI
Application Kind Code	/AK	S WOW/AK	AI, AIT
Application Kind Code Text	/AIT	S MWA/AIT	AIT
Application Number (4)	/AP	S ZW1981-215/AP	AI
Application Year (2)	/AY	S 1988/AY AND SIEMENS/PAS	AI
Changes (Indicator for the changes in the last update)	/CHG	S EPC C/CHG	CHG
Citation Category	/CAT	S X/CAT	REN, REP
Cited Application Country	/AC.D	S AT/AC.D	REAI
Cited Application Kind Code	/AK.D	S ATA/AK.D	REAI
Cited Application Number	/AP.D	S AT920000957/AP.D	REAI
Data Availability	/DAV	S NOT-PRINTED-WITH-GRANT/DAV	DAV
Data Force (2,4)	/DF	S 20070401/DF	DF
Designated States	/DS	S W JP/DS	DS
Document Type (code and text)	/DT (or /TC)	S U/DT AND UNILEVER/PAS	DT
Entry Date (2,5)	/ED	S L1 AND ED>1 JAN 2007	ED
Entry Date New Patent Family (2)	/EDF	S 20070321/EDF	EDF
Entry Date new publication and/or New Legal Status (2)	/EDLS	S EDLS=20070419	not displayed
Entry Date Patent (2,5)	/EDP	S 20061130/EDP	EDP
Entry Date Priority (2,5)	/EDPR	S 20070401-20070429/EDPR	PRAI
Entry Week (INPADOC) (2,6)	/EW	S 200801/EW	EW
EPC, Keyword Terms	/EPC.KW	S D2/EPC.KW	EPC
European Patent Classification	/EPC	S A01B0015-20/EPC	EPC
Field Availability	/FA	S L7 AND DS/FA	FA
Filing Country for PCT Application	/AC.WO	S FR/AC.WO	AI
Filing Country for PCT Priorities (WIPO code and text)	/PRC.WO	S DE/PRC.WO	PRAI
Filing Details	/FDT	S DEC3D6/FDT	FDT
Indeling der Techniek (EPO/NL)	/IDT	S 12C2P2E4/IDT	IDT
ICO (in-computer-only) Classification	/ICO	S K61M/ICO	ICO
International Patent Classification (contains ICM, ICS, ICA, ICI, IPCI, IPCR)	/IPC	S H05B0006-36+NT/IPC S H05B0006-36-H05B0006-44/IPC	IC, ICA, ICI, ICM, ICS, IPCI, IPCR
Inventor	/IN (or /AU)	S NICKOLA RICHARD?/IN	IN
Inventor Address	/INA	S HEIDELBERG/INA	INA
Inventor, Country (WIPO code and text)	/IN.CNY	S GB/IN.CNY	INS

Bibliographic Search Fields (cont'd)

Search Field Name	Search Code	Search Examples	Display Codes
Inventor INPADOC Standard IPC (contains ICM and ICS), Version 1-7 (7)	/INS /IC	S AGARWAL S?/INS S C07H019-16/IC	INS IC
IPC, Action Date	/IPC.ACD	S 13 JAN 2006/IPC.ACD	IPC.TAB
IPC, Additional (supplementary) Version 1-7 (7)	/ICA	S A61K037-64/ICA	ICA
IPC, Index (complementary) Version 1-7 (7)	/ICI	S (C12P019-40(L)C12R001:465)/ICI	ICI
IPC, Keyword Terms	/IPC.KW	S INITIAL/IPC.KW	IPC.TAB
IPC, Main, Version 1-7 (7)	/ICM	S C23C001-08/ICM	ICM
IPC, Secondary (7)	/ICS	S C12P019-40/ICS	ICS
IPC, Version from IC	/IC.VER	S 7/IC.VER AND L5	IC.VER, IC
IPC, Version from IPC	/IPC.VER	S 200601/IPC.VER	IPC.TAB
Japanese Patent Classification (FI-Terms)	/FCL	S A01B0001-24 B/FCL	FCL
Japanese Patent Classification (F-Terms)	/FTRM (or /FTRM, or /FTCLA, or /JPCLA)	S 5H030/AA00/FTRM	FTRM
Language (ISO code and text)	/LA	S DE/LA	LA
Language of Filing (ISO code and text)	/LAF	S FR/LAF	LAF
Locarno Classification	/LCL	S 3001/LCL	LCL
Non-Patent Literature XP-Document Number	/REXP	S XP002235691/REXP	REXP
Origin of Citation	/SRT	S EXA/SRT	REN, REP, REXP
Other National Classifications (10)	/OCL	S 81C,27/OCL	OCL
Patent Assignee (8)	/PA (or /CS)	S INLAND STEEL/PA S BROWN WILLIAMSON/CS	PA
Patent Assignee Address	/PAA	S US/PAA AND EASTMAN KODAK/PAS	PAA
Patent Assignee INPADOC Standard	/PAS	S INLAND STEEL CO?/PAS S (BROWN(S)TOBACCO)/PAS	PAS
Patent Assignee, Country	/PA.CNY	S GB/PA.CNY	PAS
Patent Country (WIPO code and text)	/PC	S DE/PC AND IBM/PAS AND 1988/PY	PI
Patent Information Publication Type	/PIT	S ARA1/PIT	PIT
Patent Kind Code	/PK	S ZWA1/PK	PI
Patent Number (3)	/PN	S FI990202U/PN	PI
Patent Number/Kind Code	/PNK	S WO2009006253A2/PNK	PNK
Patent Status	/STA	S GRANTED/STA AND LASER/TI	STA
Priority Country (WIPO code and text)	/PRC	S JP/PRC AND 19880101/PRD	PRAI
Priority Date (2)	/PRD	S JP/PRC AND 19880101-19880331/PRD	PRAI
Priority Date, First (2)	/PRDF	S MARCH 2009/PRDF	PRAI
Priority Kind Code	/PRK	S DEA/PRK	PRAI
Priority Kind Text	/PRAIT	S ARA PATENT APPLICATION/PRAIT	PRAIT
Priority Number (3)	/PRN	S US1990-184420/PRN	PRAI
Priority Year (2)	/PRY	S 1998/PRY AND US/PRC	PRAI
Priority Year, First (2)	/PRYF	S GB/PC AND 1998/ PRYF	PRAI
Publication Date (2)	/PD	S 19990104/PD	PI
Publication Year (2)	/PY	S 1999/PY	PI
Reference Count	/REC (or /RE.CNT)	S 8/REC	REC
Referenced Non-Patent Literature	/REN	S MAYER/REN	REN
Referenced Patent Country	/RPC (or /PC.D)	S WO/RPC	RE, REP
Referenced Patent Date	/RPD (or /PD.D)	S 19730919/RPD	REP

Bibliographic Search Fields (cont'd)

Search Field Name	Search Code	Search Examples	Display Codes
Referenced Patent Kind Code	/RPK (or /PK.D)	S EPA/RPK	REP
Referenced Patent Number	/RPN (or /PN.D)	S EP1234567/RPN	REP REP
Referenced Patent Year	/RPY	S 2010/RPY	
Search Report Office (WIPO code and text)	(or /PY.D) /SRO	S CH/SRO	REP
Title*	/TI	S (APPARAT? (S) SMOKE (S) FILTER#)/TI	TI
Title Language (ISO code and text)	/TL	S EN/TL S ENGLISH/TL	TL TL
Update Date (2)	/UP	S L1 AND UP>20070102	UP
Update Date All Patent Changes (2)	/UPM	S L1 AND 20070222/UPM	not displayed
Update Date Classifications (2)	/UPCC	S L1 AND UPCC>20070222	UPALL
Update Date for combined or split Patent Family (9)	/UPFC	S UPFC=OCT 2009	UPALL
Update Date Legal Status (2)	/UPLS	S UPLS=20070222	LS, LSUP
Update Date New Publication and/or Legal Status Changes (2)	/UPFE	S 20070321/UPFE	UPALL
Update Date of the BIB fields (2)	/UPBB	S L1 AND UPBB>20070222	UPALL
Update Date Patent Family (2) (All Updates)	/UPFA	S 20070329/UPFA	UPALL
Update Date New Patent Family Record (2)	/UPFD	S 20070215/UPFD	UPALL
Update Date Patent Family Legal Status (2)	/UPFL	S 20070321/UPFL	UPALL
Update Date Patent Family Publication Level (2)	/UPFP	S 20070222/UPFP	UPALL
Update Date Patent Family Bibliographic (2)	/UPFB	S 20070215/UPFB AND L7	UPALL
Update Week (INPADOC Week) (2)	/UW	S UW=200641 AND L3	UW
US National Classification, Current	/NCL	S 455289000/NCL	NCL
US National Classification, Current (main)	/NCLM	S 455289000/NCLM	NCL
US National Classification, Current (secondary)	/NCLS	S 455289000/NCLS	NCL
US National Classification, Issued	/INCL)	S 455289000/INCL	INCL
US National Classification, Issued (main)	/INCLM)	S 455289000/INCLM	INCL
US National Classification, Issued (secondary)	/INCLS)	S 455289000/INCLS	INCL

- (1) This field is available for selected countries and patent publications.
(2) Numeric search field that may be searched using numeric operators or ranges.
(3) Either STN or Derwent format may be used.
(4) For German Utility Models: Advertisement of registration.
(5) Available since 2006.
(6) Available since week 200639
(7) Search in IPC8 format also available.
(8) Search with implied (S) proximity is available.
(9) Available since September 2009.
(10) Selected coverage for DE, GB, CH, CA, AT, SE, DK, BR, MX, AU, ES, NL.

Legal Status Search Fields

Search Field Name	Search Code	Search Examples	Display Codes
Entry Date New Publication and/or New Legal Status (1)	/EDLS	S EDLS=FEB 2009	not displayed
Entry Week Legal Status	/EWLS	S 200641-200642/EWLS	LS2
Legal Status Basic Index (contains legal status agent (LSAG), legal status free format text (LSFT), legal status inventor (LSIN), legal status patent opponent (LSOP), and legal status patent assignee (LSPA) fields)	/LSBI	S LASER?/LSBI S ANACOMP/LSBI S OPPOSITE/LSBI	LS
Legal Status Code (code and text)	/LSC	S EP111L/LSC	LS
Legal Status Code Category	/LSC2	S NIF/LSC2	LS
Legal Status Code Country (WIPO code and text)	/LSCC	S BE/LSCC	LS
Legal Status Country (WIPO code and text)	/LSCY	S UNITED KINGDOM/LSCY	LS
Legal Status Date in Force (1)	/LSDF	S LSDF=20050109	LS
Legal Status Date INPADOC GAZETTE (1)	/LSD	S LSD=JAN 2002	LS
Legal Status Designated States (WIPO code and text)	/LSDS	S AU/LSDS S AUSTRALIA/LSDS	LS
Legal Status Free Format Text	/LSFT	S TELECOMMUNICATION/LSFT	LS
Legal Status Indicator	/LSCI	S POSITIVE/LSCI AND L3	LS
Legal Status IPC	/LSIC	S 41J320/0/LSIC	LS
Legal Status Patent Assignee	/LSPA	S (MAN(S)CERAMICS)/LSPA	LS
Legal Status Patent Inventor	/LSIN	S MAYER, BERND/LSIN S (MAYER(S)BERND)/LSIN	LS
Legal Status Patent Opponent	/LSOP	S SIEMENS AG/LSOP	LS
Legal Status Payment Year (1)	/LSPMY	S 18/LSPMY	LS
Legal Status Publication Country (WIPO code and text)	/LSPC	S CA/LSPC S CANADA/LSPC	LS
Legal Status Publication Date (1)	/LSPD	S LSPD=JAN 1998	LS
Legal Status Publication Kind Code	/LSPK	S ES00/LSPK	LS
Legal Status Publication Number	/LSPN	S EP200212/LSPN	LS
Legal Status Publication Year (1)	/LSPY	S 1999-2000/LSPY	LS
Legal Status Represent./Agent	/LSAG	S (LORENZ AND PHILIPPS)/LSAG	LS
Legal Status Code Text	/LSTX	S CORRECTION/LSTX	LS
Legal Status SPC Number	/LSSPC	S EU/1/00/129/001/LSSPC	LS
Legal Status SPC, Expiry Date (1)	/LSSPC.XD	S LSSPC.XD>2005	LS
Legal Status SPC, Extension Date (1)	/LSSPC.EX	S 20010910/LSSPC.EX	LS
Legal Status SPC, Filing Date (1)	/LSSPC.FD	S 19950101-19961231/LSSPC.FD	LS
Update Legal Status (1)	/UPLS	S 20070208/UPLS	LS, LSUP

(1) Numeric search field that may be searched using numeric operators or ranges.

Super Search Fields

Enter a super search code to execute a search in one or more fields that may contain the desired information. Super search fields facilitate crossfile and multfile searching. EXPAND may not be used with super search fields. Use EXPAND with the individual field codes instead.

Search Field Name	Search Code	Fields Searched	Search Examples	Display Codes
Application Number Group (1)	/APPS	/AP, /PRN	S DE1984-3400052/APPS S 1984DE-3400052/APPS	AI, PRAI
EPC, All	/ECLA.ALL	/EPC, /ICO	S A01B0017-00D/ECLA.ALL	EPC, ICO
Inventor Group	/INSS	/IN, /INS, /LSIN	S MEIER/INSS	IPC
Patent Assignee Group	/PASS	/PA, /PAS, /LSPA	S MEIER/PASS	PI
Patent Countries	/PCS	/PC,/DS	S BE/PCS	PI, DS
Patent Number Group (1)	/PATS	/PN, /RPN	S WO1989004114/PATS	PI, REP

(1) Either STN format or Derwent format may be used.

IPC THESAURUS

The classifications, validity and catchwords for the main headings and subheadings from the current (8th) edition of the WIPO International Patent Classification (IPC) manual are available. The classifications from the previous editions (1-7) are also available as separate thesauri. To EXPAND and SEARCH in the thesauri for editions 1-8, use the field code followed by the edition number, e.g., /IPC2 for the 2nd edition. Catchwords are included only in the thesauri for the 8th, 7th, 6th, and 5th editions.

Code	Content	Examples
ADVANCED (ADV)	Advanced Level Codes for the Core Level IPC Code	E A61K0066-02+ADVANCED/IPC
ALL	All Associated Terms (BT, SELF, NT, RT)	E C01C003-00+ALL/IPC
BRO (MAN)	Complete Class	E C01C+BRO/IPC
BT	Broader Term (SELF, BT)	E C01F001-00+BT/IPC
BTn	Broader Term (SELF, BT) up to the next n levels (n =1,2,...)	E C01F001-21+BT2/IPC
CORE (COR)	Core Codes for the Advanced Level IPC Code	E G08C0019-22+CORE/IPC
ED	Complete title of the SELF term and IPC manual	E C01F001-00+ED/IPC
HIE	Hierarchy Term (Broader and Narrower Term) (BT, SELF, NT)	E C011003-00+HIE/IPC
INDEX	Complete title of the SELF term	E C01F001-00+INDEX/IPC
KT	Keyword Term (catchwords) (SELF, KT)	E CYANOGEN+KT/IPC
NEXT	Next Classification	E C01C001-00+NEXT5/IPC
NT	Narrower Terms (SELF, NT)	E C01C+NT/IPC
NTn	Narrower Terms (SELF, NT) down to the next n levels (n =1,2,...)	E C01C+NT3/IPC
PREV	Previous Code within the same class (SELF, PREV)	E C01C001-12+PREV/IPC
PREV(n)	Previous n classifications within the same class	E C01C001-12+PREV10/IPC
RT (SIB)	Related Terms (SELF, RT)	E C01C003-20+RT/IPC
TI	Complete Title of the SELF Term and Broader Terms (BT, SELF)	E C01F001-00+TI/IPC

ECLA (/EPC) and ICO Thesauri

These thesauri are available in the /EPC search field (for ECLA codes) and /ICO search field (for 'in-computer-only' codes). All relationship codes can be used with both the EXPAND and SEARCH commands.

Relationship Code	Content	Search Examples
ALL AUTO (1) BT CODE	All usually required terms (BT, SELF, CODE, DEF) Automatic relationship (BT, SELF, CODE, DEF) Broader terms (BT, SELF) Classification Code (SELF, CODE)	E C12M0001-34H2+ALL/EPC E G01J0003-443+AUTO/EPC E G01J0003-443+BT/EPC E SCRAPER BIASING MEANS+CODE/EPC
DEF HIE	Definition (SELF, DEF) Hierarchy terms (all broader and narrower terms) (BT, SELF, DEF, NT)	E B65G0045-16+DEF/EPC E A01B0001+HIE/EPC
KT MAX NEXT NEXT(n) NT PREV PREV(n) TI	Keyword terms (SELF, KT) All associated terms Next classification within the same class (SELF, NEXT) Next n classification within the same class Narrower terms Previous Code within the same class (SELF, PREV) Previous n classifications within the same class Complete Title of the SELF Term and Broader Terms (BT, SELF)	E LASER+KT/EPC E G01J0003-44B+MAX/EPC E A01B0001-24+NEXT/EPC E A01B0001-24+NEXT3/EPC E G05B0001-04+NT/EPC E G05B0019-418N1+PREV/EPC E G05B0019-418N1+PREV2/EPC E G05B0001-03+TI/EPC

(1) Automatic Relationship is SET OFF. In case of SET REL ON the result of EXPAND or SEARCH without any relationship code is the same as described for AUTO.

US National Patent Classification (/NCL, /INCL) Thesaurus

The US National Patent Classification thesaurus is available online in field /NCL and /INCL. All relationship codes can be used with both the EXPAND and SEARCH commands.

Relationship Code	Content	Search Examples
ALL AUTO (1) BT CODE DEF HIE KT MAX	All usually required terms (BT, SELF, DEF, NT) Automatic relationship (BT, SELF, DEF, NT) Broader Terms (BT, SELF) Classification Code (SELF, CODE) Definition (SELF, DEF, DEF2, DEF3, DEF4) Hierarchy Terms (BT, SELF, DEF, NT) Keyword Terms (SELF, KT) All associated Terms (BT, SELF, DEF, DEF2, DEF3, DEF4, NT, KT)	E 257E21685+ALL/NCL E 02416300R+AUTO/NCL E 02416300R+BT/NCL E APPAREL+CODE/NCL E G9B031001+DEF/NCL E 23548700+HIE/NCL E APPAREL+KT/NCL E G9B031000+MAX/NCL
NEXT NEXT(n) NT PREV PREV(n) TI	Next classification within the same class Next n classifications within the same class Narrower Terms (SELF, NT) Previous Code within the same class Previous n classifications within the same class Complete title including Broader Terms (SELF, BT, DEF (BT))	E G9B033035+NEXT/NCL E G9B033035+NEXT2/NCL S 257E21685+NT/NCL E 235462260+PREV/NCL E 235462260+PREV3/NCL E 052002110+TI/NCL

(1) Automatic Relationship is SET OFF. In case of SET REL ON the result of EXPAND or SEARCH without any relationship code is the same as described for AUTO.

DISPLAY and PRINT Formats

Any combination of formats may be used to display or print answers. Multiple codes must be separated by spaces or commas, e.g., D L1 1-5 TI PI. The fields are displayed or printed in the order requested.

All custom display fields provide the deduplicated content of all publications of a record (national family).

You can combine all display fields and all display formats with the qualifier .M to display the content for all publications of a record.

You can combine all display fields and all display formats with the qualifier .F to display the content for all family members (will be charged as a family display).

Hit-term highlighting is available for all fields. Highlighting must be ON during SEARCH to use the HIT, KWIC, and OCC formats.

Format	Content	Examples
AB	Abstract in English	D AB
ABDE	Abstract in German	D ABDE
ABES	Abstract in Spanish	D ABES
ABEQ (1)	Display of an English equivalent abstract	D ABS
ABFR	Abstract in French	D ABFR
ABOL	Abstract in Other Language	D ABOL
AI (2)	Application Information	D AI
AIT	Application Kind Code Text	D AIT
AN	Accession Number	D AN
CHG	Changes (Indicator for changes in the last update)	D CHG
DAV	Data Availability	D DAV
DF	Date of Force	D DF
DS	Designated States	D DS
DT (TC)	Document Type	D DT
ED	Entry Date	D ED
EDP	Entry Date Patent	D EDP
EPC (ECLA)	European Patent Classifications (EPC, ICO, IDT)	D EPC
EW	Entry Week	D EW
FA	Field Availability	D FA
FCL (JPC)	Japanese Patent Classification (FI-Terms)	D FCL
FDT (PT)	Filing Details	D FDT
FN	Family Number	D FN
FTRM (FTERM, FTCLA, JPCLA)	Japanese Patent Classification (F-Terms)	D FTRM
GI	Graphic Image	D GI
IC	International Patent Classification (ICM, ICS)	D IC
ICA	IPC, Additional (supplementary)	D ICA
ICI	IPC, Index (complementary)	D ICI
ICM	IPC, Main	D ICM
ICO	ICO (in-computer-only) Classification	D ICO
ICS	IPC, Secondary	D ICS
IN	Inventor	D IN
IN.CNY	Inventor, Country	D INS
INA	Inventor Address	D INA
INCL	US National Classification, Issued	D INCL
INCLM	US National Classification, Issued (main)	D INCL
INCLS	US National Classification, Issued (secondary)	D INCL
INS	Inventor INPADOC Standard	D INS
IPCI	IPC, Initial	D IPCI
IPCR	IPC, Reclassified	D IPCR
LA	Language	D LA
LAF	Language of Filing	D LAF
LCL	Locarno Classification	D LCL
NCL	US National Classification, Current	D NCL
NCLM	US National Classification, Current (main)	D NCL
NCLS	US National Classification, Current (secondary)	D NCL
OCL	Other National Classifications	D OCL

DISPLAY and PRINT Formats (cont'd)

Format	Content	Examples
PA (CS) PAA PA.CNY PAS PI (PN) (2) PIT PNK PRAI (PRN) (2) PRAIT REAI REC (RE.CNT) REN (NPL) REP REXP STA TI TL UP UW	Patent Assignee Patent Assignee Address Patent Assignee, Country Patent Assignee INPADOC Standard Patent Information Patent Information Publication Type Patent Number/Kind Code Priority Information Priority Kind Text Referenced Application Information Reference Count Referenced Non-Patent Literature Referenced Patents Non-Patent Literature XP-Document Number Status Title Title Language Update Date Update Week (INPADOC Week)	D PA D PAA D PAS D PAS D PI D PIT D PNK D PRAI D PRAIT D REP D REC D REN D REP D REXP D STA D TI D TL D UP D UW
ABS (1) ALL (2) ALLG ALLO (2) IALL (2) IALLG BIB (2) IBIB (2) APPS (2) BRIEF BRIEFG IND IPC IPC.TAB LS LS2 LSUP MAX (2) MAXG IMAX (2) IMAXG MAXO (2) MAXO2 (2) PATS (2) RE SCAN (3) STD (2) STDG TRIAL (TRI, FREE, SAMPLE, SAM)	AN, AB, ABDE, ABES, ABFR, ABOL, ABEQ BIB, all Abstracts, IND, FA, CHG ALL, plus graphic image ALL, for previous update ALL, indented with text labels IALL, plus graphic image AN, ED, EW, UP, UW, FN, UPFC, TI, TL, IN, INS, INA, PA, PAS, PAA, DT, LA, LAF, PI, PIT, DAV, STA, DF, DS, XS, AI, AIT, PRAI, PRAIT, REC (The default format is BIB.M) BIB, indented with text labels Application Number Group (AI, PRAI) TI, INS, PAS, IPCI, IPCR, EPC, NCL, INCL, FTRM, FCL, LCL, PI, AI, PRAI, abstracts BRIEF, plus graphic image AN, ED, EW, UP, UW, IPC, EPC, ICO, IDT, NCL, INCL, FTRM, FCL, LCL ICM, ICS, ICA, ICI, IPCR, IPCI IPC, IPC.KW, IPC.ACD, IPC.VER, in tabular display AN, UPLS, Legal Status Legal Status, detailed version with display headers Last LS Update ALL.M plus all Abstracts, PRAIT, RLI, AIT, FDT, LS, SFN MAX, plus graphic image MAX, indented with text labels IMAX, plus graphic image MAX, with original data in UTF-8 characters MAXO, plus display of special characters in the abstract Patent Number Group (PI, REP) Cited References (REP, REXP, REAI, REN) TI latest publication (random display without answer number) BIB, IND STD, plus graphic image TI, FA	D ABS D ALL D ALLG D ALLO D IALL D IALLG D BIB D IBIB D APPS D BRIEF D BRIEFG D IND D IPC D IPC.TAB D LS D LS2 D LSUP D MAX D MAXG D IMAX D IMAXG D MAXO D MAXO2 D PATS D RE D SCAN D STD D STDG D TRIAL
HIT KWIC OCC	Hit term(s) and field(s) Up to 50 words before and after hit term(s) (KeyWord-In-Context) Number of occurrences of hit term(s) and field(s) in which they occur	D HIT D KWIC D OCC

(1) ABEQ only for records entered or updated after week 200740.

- (2) Application, patent, and priority number are available in STN and Derwent format. The format for DISPLAY, PRINT, SELECT, and SORT is set using the SET PATENT command. STN is the default format. Enter SET PAT DERWENT to change to the Derwent format. To reset to the STN format, enter SET PAT STN.
- (3) SCAN must be specified on the command line, i.e., D SCAN or DISPLAY SCAN.

FAMILY DISPLAY and PRINT Formats

Format	Content	Examples
TIPI.F	TI + LS for all patent family members	D TIPI.F
PILS.F (1)	PI + LS for all patent family members	D PILS.F
BIBLS (1)	BIB + LS for all patent family members	D BIBLS
CFAM (1)	Condensed FAM with only PI in the table	D CFAM
CFAM2 (1)	Display for the condensed family table PI, AI, PRAI	D CFAM2
DFAM (1,2)	FAM, delimited for post processing	D DFAM
DFAM.AD	DFAM, sorted by Application Date	D DFAM.AD
DFAM.AP	DFAM, sorted by Application Number	D DFAM.AP
DFAM.PD	DFAM, sorted by Patent Date	D DFAM.PD
DFAM.PN	DFAM, sorted by Patent Number	D DFAM.PN
DFAM.PRD	DFAM, sorted by Priority Date	D DFAM.PRD
EFAM (1)	FAM, but the priority information constitutes the header	D EFAM
EFAM.PRD	EFAM, sorted by Priority Date	D EFAM.PRD
FAM (1)	AN, table of patent family information	D FAM
FAM.PRD	AN, table of patent family information, sorted by Priority Date	D FAM.PRD
FAMLS (1)	Comprises the family table CFAM2 plus a list of all legal status entries, sorted by legal status date LSD	D FAMLS
FAM2 (1)	AN, table of patent family information, another order	D FAM2
FFAM (1)	STD + LS for each member of the family	D FFAM
FFAM.PC (1,3)	FFAM for a specified country only	D FFAM.PC
FFAM.G	FFAM, plus graphic image	D FFAM.G
IFAM (1)	Combines indented FAM and IMAX.F	D IFAM
IFAMG	IFAM, plus graphic image	D IFAMG
LFAM (1)	AN, PI, LSUP for all members of a patent family	D LFAM
MFAM (1)	MAX for each family member	D MFAM
MFAMG	MFAM, plus graphic image	D MFAMG
SFAM (1)	Display of the EPO 'simple patent family' (SFN) within the INPADOC patent family table	D SFAM
UPALL	Table of update dates (AN, FN, UPFC, UPBB, UPCC, ED, EDP, UPFB, UPFP, UPFD, EDF, UPFL)	D UPALL

- (1) Application, patent, and priority number are available in STN and Derwent format. The format for DISPLAY, PRINT, SELECT, and SORT is set using the SET PATENT command. STN is the default format. Enter SET PAT DERWENT to change to the Derwent format. To reset to the STN format, enter SET PAT STN.
- (2) SET LINE 100 is recommended.
- (3) PC = AT BE CA CH CN DE DK EP ES FI FR GB JP KR NO RU SE US WO

FAMILY DISPLAY and PRINT Formats – Weekly SDI

Format	Content	Examples
FFAMED (1)	STD for new publications and/or LSUP for each updated family	D FFAMED
FFAMED.PC (1,2)	FFAMED for a specific country only	D FFAMED.PC
FFAMUP (1)	STD + LS for each updated family	D FFAMUP
FFAMUP.PC (1,2)	FFAMUP for a specific country only	D FFAMUP.PC
IFAMED (1)	Indented FFAMED plus patent family table	D IFAMED
IFAMUP (1)	Indented FFAMUP plus patent family table	D IFAMUP
LFAMUP (1)	AN, PI, LSUP for all updated members of a patent family	D LFAMUP
LFAMUP.PC (1,2)	LFAMUP for a specific country only	D LFAMUP.PC

- (1) Application, patent, and priority number are available in STN and Derwent format. The format for DISPLAY, PRINT, SELECT, and SORT is set using the SET PATENT command. STN is the default format. Enter SET PAT DERWENT to change to the Derwent format. To reset to the STN format, enter SET PAT STN.
- (2) PC = AT BE CA CH CN DE DK EP ES FI FR GB JP KR NO RU SE US WO

FAMILY DISPLAY and PRINT Formats – Monthly SDI

Format	Content	Examples
FFAMED4 (1) FFAMUP4 (1) IFAMED4 (1) IFAMUP4 (1) LFAMUP4 (1)	STD for new publications and/or LSUP for each updated family STD + LS for each updated family Indented FFAMED4 plus patent family table Indented FFAMUP4 plus patent family table AN, PI, LSUP for all updated members of a patent family	D FFAMED4 D FFAMUP4 D IFAMED4 D IFAMUP4 D LFAMUP4

(1) Application, patent, and priority number are available in STN and Derwent format. The format for DISPLAY, PRINT, SELECT, and SORT is set using the SET PATENT command. STN is the default format. Enter SET PAT DERWENT to change to the Derwent format. To reset to the STN format, enter SET PAT STN.

Sorting within the PATENT FAMILY DISPLAY Formats

Format	Content
FAM DFAM EFAM FFAM LFAM CFAM	PRN (Priority Number) PRN (Priority Number) PRN (Priority Number) PN (Patent Number) of the highest level PN (Patent Number) of the highest level AP (Application Number)

You can define the sort parameter in family display formats. Depending on the formats used, options are priority date (.PRD), publication date (.PD), patent number (.AP), application date (.AD). The following combinations are available.

Format	Content
FAM.PRD CFAM.PD DFAM.PRD DFAM.AP DFAM.AD DFAM.PN DFAM.PD EFAM.PRD	Priority Date Publication Date Priority Date Application Number Application Date Patent Number Patent/Publication Date Priority Date

SELECT, ANALYZE, and SORT Fields

The SELECT command is used to create E-numbers containing terms taken from the specified field in an answer set.

The ANALYZE command is used to create an L-number containing terms taken from the specified field in an answer set.

The SORT command is used to rearrange the search results in either alphabetic or numeric order of the specified field(s).

SELECT, ANALYZE, and SORT Fields (cont'd)

Field Name	Field Code	ANALYZE/ SELECT (1)	SORT
Abstract in English	AB	Y	Y
Abstract in French	ABFR	Y (2)	Y
Abstract in German	ABDE	Y (2)	Y
Abstract in Other Language	ABOL	Y (2)	Y
Abstract in Spanish	ABES	Y (2)	Y
Application Country	AC	Y	Y
Application Date	AD	Y	Y
Application Kind Code	AK	Y	Y
Application Kind Code Text	AIT	Y	Y
Application Number	AP (AI)	Y (3)	Y
Application Number Group	APPS	Y (3,4)	N
Application Year	AY	Y	Y
Changes (Indicator for the changes in the last update)	CHG	Y	N
Cited Application Country	AC.D	Y	N
Cited Application Kind Code	AK.D	Y	N
Cited Application Number	AP.D	Y	N
Date of Force	DF	Y	Y
Designated State	DS	Y	N
Document Type	DT (TC)	Y	Y
Entry Date	ED	Y	N
Entry Date Patent	EDP	Y	N
Entry Week	EW	Y	N
European Patent Classification	EPC (ECLA)	Y	Y
ICO (in-computer-only) Classification	ICO	Y	Y
Indeling der Techniek (EPO/NL)	IDT	Y	Y
International Patent Classification	IC	Y	N
International Patent Classification	IPC	Y	Y
Inventor	IN (AU)	Y	Y
Inventor Address	INA	Y	Y
Inventor Address, Country	IN.CNY	Y	Y
Inventor INPADOC Standard	INS	Y	Y
IPC, Additional (supplementary)	ICA	Y	Y
IPC, Advanced Level Symbols	IPC.A	Y (5)	N
IPC, Advanced Level Symbols for Invention	IPC.AI	Y (5)	N
IPC, Core Level Symbols	IPC.C	Y (5)	N
IPC, Core Level Symbols for Invention	IPC.CI	Y (5)	N
IPC, Index (complementary)	ICI	Y	Y
IPC, Initial	IPCI	Y (5)	N
IPC, Main	ICM	Y	Y
IPC, Reclassified	IPCR	Y (5)	N
IPC, Secondary	ICS	Y	Y
Japanese Patent Classification (F-Terms)	FTRM	Y	N
Japanese Patent Classification (FI-Terms)	FCL	Y	N
Language	LA	Y	Y
Language of Filing	LAF	Y	Y
Locarno Classification	LCL	Y	Y
Legal Status Code	LSC	Y	N
Legal Status Code Category	LSC2	Y	N
Legal Status Code Country	LSCC	Y	N
Legal Status Date INPADOC GAZETTE	LSD	Y	N
Legal Status Free Format Text	LSFT	Y	N
Legal Status IPC	LSIC	Y	N
Legal Status Patent Assignee	LSPA	Y	N
Legal Status Patent Inventor	LSIN	Y	N
Legal Status Patent Opponent	LSOP	Y	N
Legal Status Payment Year	LSPMY	Y	N
Legal Status Publication Country	LSPC	Y	N
Legal Status Publication Date	LSPD	Y	N

SELECT, ANALYZE, and SORT Fields (cont'd)

Field Name	Field Code	ANALYZE/ SELECT (1)	SORT
Legal Status Publication Number	LSPN	Y	N
Legal Status Representative/Agent	LSAG	Y	N
Legal Status SPC Number	LSSPC	Y	N
Legal Status SPC, Expiry Date	LSSPC.XD	Y	N
Legal Status SPC, Extension Date	LSSPC.EX	Y	N
Legal Status SPC, Filing Date	LSSPC.FD	Y	N
US National Classification, Current	NCL	Y	Y
US National Classification, Current (main)	NCLM	Y	N
US National Classification, Current (secondary)	NCLS	Y	N
US National Classification, Issued	INCL	Y	N
US National Classification, Issued (main)	INCLM	Y	N
US National Classification, Issued (secondary)	INCLS	Y	N
Occurrence Count of Hit Terms	OCC	N	Y
Other National Classifications	OCL	Y	Y
Patent Assignee	PA (CS)	Y	Y
Patent Assignee Address	PAA	Y	Y
Patent Assignee INPADOC Standard	PAS	Y	Y
Patent Assignee Standard, Cited	PAS.D	Y	N
Patent Assignee, Country	PA.CNY	Y	Y
Patent Country	PC	Y	Y
Patent Information Publication Type	PIT	Y	Y
Patent Kind Code	PK	Y	Y
Patent Number	PN (PI)	Y (3)	Y
Patent Number/Kind Code	PNK	Y	N
Patent Number Group	PATS	Y (3,6)	Y
Pre-IPC8 Symbols from the ICM and first IPC8 values from 2006 to the present	IPC.F	Y (5)	Y
Priority Country	PRC	Y	Y
Priority Country, First	PRCF	Y	Y
Priority Country, First of PCT Priorities	PRCF.WO	Y	Y
Priority Date	PRD	Y	Y
Priority Date, First	PRDF	Y	Y
Priority Kind Code	PRK	Y	Y
Priority Kind Text	PRAIT	Y	Y
Priority Number	PRN (PRAI)	Y (3)	Y
Priority Year	PRY	Y	Y
Priority Year, First	PRYF	Y (7)	Y
Publication Date	PD	Y	Y
Publication Year	PY	Y	Y
Referenced Non-Patent Literature	REN	Y	Y
Referenced Non-Patent Literature XP-Document Number	REXP	Y	Y
Referenced Patent Country	RPC (PC.D)	Y	N
Referenced Patent Date	RPD (PD.D)	Y	N
Referenced Patent Kind Code	RPK (PK.D)	Y	N
Referenced Patent Number	RPN (PN.D)	Y	N
Referenced Patent Year	RPY (PY.D)	Y	N
Referenced Patents	REP	Y	Y
Title	TI	Y (default)	Y
Title Language	TL	Y	Y
Update Date	UP	Y	N
Update Week	UW	Y	N

(1) HIT may be used to restrict terms extracted to terms that match the search expression used to create the answer set, e.g., SEL HIT TI.

(2) Appends /AB to the terms created by SELECT.

(3) SELECTed and SORTed application, priority and patent numbers are in the format set by the Messenger SET PATENT command, either DERWENT or STN.

(4) Selects or analyzes AP, PRN, and appends /APPS to the terms created by SELECT.

(5) Appends /IPC to the terms created by SELECT.

(6) Selects or analyzes /PN, /RPN with /PATS appended to the terms created by SELECT.

(7) SELECT or ANALYZE HIT are not valid with this field.

Update Codes (for SDI also)

Update codes or entry dates associated with records

Field Name	Search Code	Search Examples	Display Codes
Entry Date	/ED	S L1 AND ED>DEC 2006	ED
Entry Date + Legal Status Update	/EDLS	S EDLS = JAN 2008	not displayed
Entry Date Patent	/EDP	S 20061026/EDP	EDP, UPALL
Entry Date Priority	/EDPR	S 29 JAN 2009/EDPR	PRAI
Update Date	/UP	S 20070102/UP	LS
Update Legal Status	/UPLS	S 20070222/UPLS	LS
All updates of a record	/UPM	S 20070215/UPM	not displayed

Update codes or entry dates associated with patent families (1,2)

Field Name	Search Code	Search Examples	Display Codes
Entry Date new patent family	/EDF	S L1 AND EDF>21 MAR 2007	UPALL
All changes in a patent family	/UPFA	S L1 AND 20070329/UPFA	not displayed
Any change of a bibliographic element in a patent family	/UPFB	S L1 AND 20070215/UPFB	UPALL
Update Date for combined or split Patent Family (3)	/UPFC	S L1 AND UPFC=OCT 2009	UPFC
Entry of a new database record (document) into a patent family (level 1)	/UPFD	S L1 AND 20070215/UPFD	UPALL
Entry of a new publication and changes in legal status	/UPFE	S L1 AND 20070321/UPFE	not displayed
Any change of a legal status in a patent family	/UPFL	S L1 AND 20070321/UPFL	UPALL
Entry of a new publication level into a patent family	/UPFP	S L1 AND 20070222/UPFP	UPALL

- (1) Available since February 2007.
 (2) Special display formats available for monitoring patent families weekly.
 (3) Available since September 2009.

Sample Records

DISPLAY MAXG

AN 24180089 INPADOCDB [Full-text](#)
 FN 13550763
 TI Verfahren und Vorrichtung zum Schneiden eines beschichteten Blattes.
 Coated sheet cutting method and apparatus.
 Procédé et appareil pour la coupe d'une feuille revêtu.
 TL German; English; French
 IN KAWAI, HIROKAZU
 INS KAWAI HIROKAZU, JP
 PA FUJI PHOTO FILM CO., LTD.
 PAS FUJI PHOTO FILM CO LTD, JP
 DT Patent
 PI EP 1488896 A1 20041222 English
 PIT EPA1 APPLICATION PUBLISHED WITH SEARCH REPORT
 DAV 20041222 examined-printed-without-grant
 STA PRE-GRANT PUBLICATION

INPADOCDB

DS R: DE FR GB
 AI EP 2004-13971 A 20040615
 AIT EPA Patent application
 PRAI JP 2003-174783 A 20030619 (JPA, 20070816, Y)
 JP 2003-174784 A 20030619 (JPA, 20070816, Y)
 PRAIT JPA Patent application
 REP JP 2001138285 A (SEA, npl, Cat: Y)
 SONY CORP
 JP 06168444 A (SEA, npl, Cat: Y)
 MATSUSHITA ELECTRIC IND CO LTD
 REXP XP000510813 (SEA, Cat: A)
 REN (1) PATENT ABSTRACTS OF JAPAN vol. 2000, no. 22, 9 March 2001
 (2001-03-09) & JP 2001 138285 A (SONY CORP), 22 May 2001 (2001-05-22)
 (SEA, Cat: Y)
 (2) PATENT ABSTRACTS OF JAPAN vol. 0185, no. 05 (P-1803), 21 September
 1994 (1994-09-21) & JP 6 168444 A (MATSUSHITA ELECTRIC IND CO LTD), 14
 June 1994 (1994-06-14) (SEA, Cat: Y)
 (3) KLEIN H: "LANGSSCHNEIDEN VON BAHNFORMIGEN MATERIALIEN DER
 KREISMESSER-SCHERENSCHNITT UND SEINE OPTIMALE EINSTELLUNG FUR DAS
 LANGSSCHNEIDEN BAHNFORMIGER MATERIALIEN (TEIL 3)" COATING, VERLAG COATING
 THOMAS & CO, CH, vol. 28, no. 5, 1 May 1995 (1995-05-01), pages 176-179,
 XP000510813 ISSN: 0590-8450 (SEA, Cat: A)
 REC 5. THERE ARE 5 CITED REFERENCES (2 PATENT, 3 NON PATENT) AVAILABLE FOR
 THIS RECORD.
 IC.V 7
 ICM B26D001-24
 IPCR B26D0001-24 [I,A]; B26D0007-26 [N,A]
 EPC B26D0001-24B
 ICO L26D0007:26C2
 AB A discoid lower blade and a discoid upper blade, having a sharper knife
 angle compared with that of the lower blade, are arranged such that
 rotational axes thereof are parallel to each other, and portions of the
 blades overlap one another in the direction that the rotational axes
 extend. A sheet with a coating layer on one side is fed through and shear-
 cut between the upper and lower blades in the direction perpendicular to
 the rotational axes, with the surface of the sheet opposite the coating
 layer in contact with a periphery of the lower blade while the blades are
 rotated. When the sheet is shear-cut, a contact start position, where
 contact between the sheet and the upper blade starts, is positioned
 upstream in the feed direction of the sheet but outside a contacting area
 of the sheet, where the sheet contacts the periphery of the lower cutting
 blade. Alternatively, the contact start position starts within the
 contacting area and an overlap between a part of the upper cutting blade
 and a part of the lower cutting blade is maintained less than 1.5 mm.
 <IMAGE>.
 AL English
 AS EPO
 FA AB; AI; AN; DAV; DS; DT; EPC; ICM; ICO; IN; INS; IPC; IPCR; LA; PA; PAS;
 PI; PIT; PRAI; REN; REP; REXP; TI

FIG.3

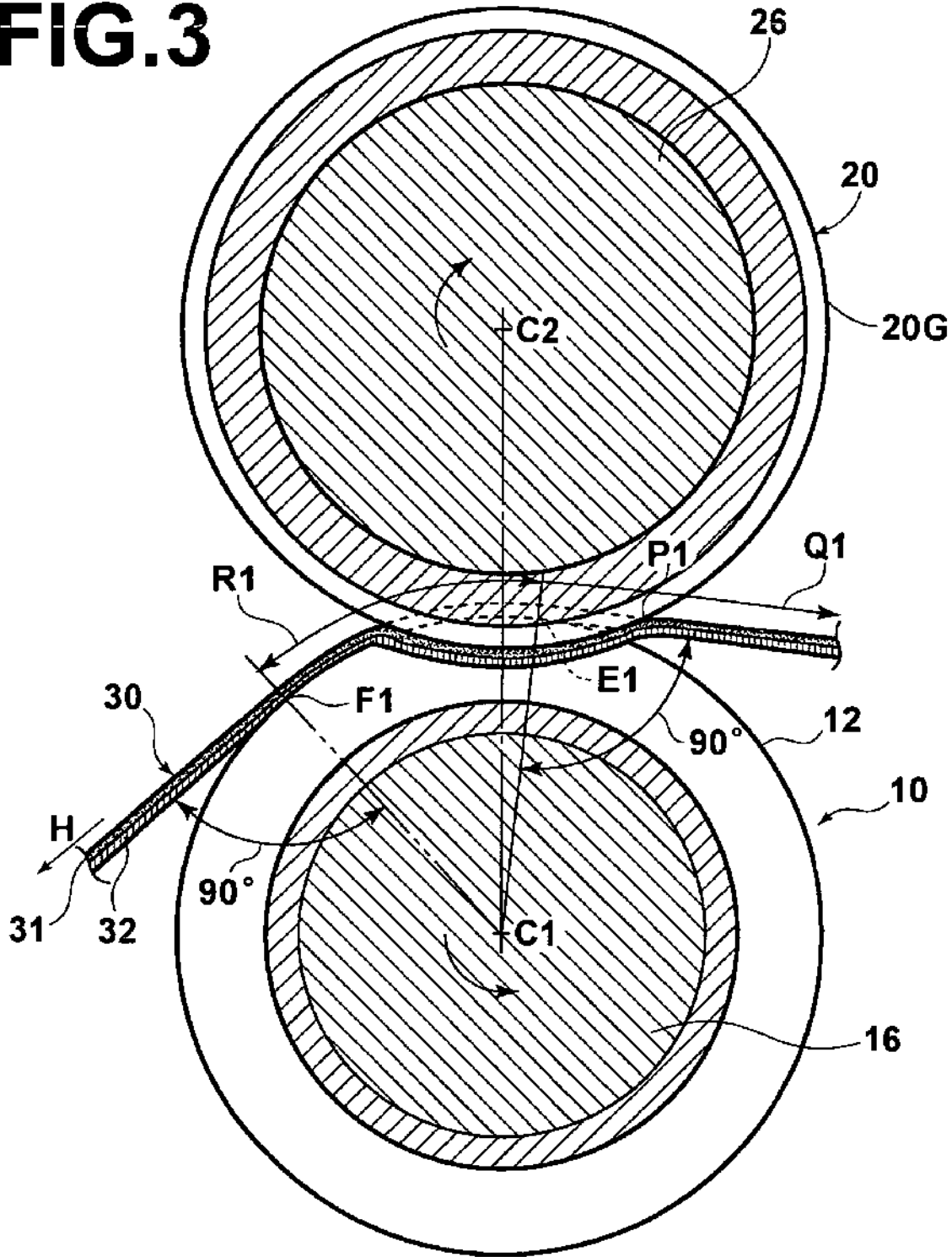

AN 24180089 INPADOCDB [Full-text](#)

FN 13550763

TI Verfahren und Vorrichtung zum Schneiden eines beschichteten Blattes.
Coated sheet cutting method and apparatus.
Procede et appareil pour la coupe d'une feuille revetue.

INPADOCDB

TL German; English; French
 IN KAWAI, HIROKAZU
 INS KAWAI HIROKAZU, JP
 PA FUJI PHOTO FILM CO., LTD.
 PAS FUJI PHOTO FILM CO LTD, JP
 DT Patent
 PI EP 1488896 B1 20061004 English
 PIT EPB1 PATENT SPECIFICATION
 DAV 20061004 printed-with-grant
 STA GRANTED
 DS R: DE FR GB
 AI EP 2004-13971 A 20040615
 AIT EPA Patent application
 PRAI JP 2003-174783 A 20030619 (JPA, 20070816, Y)
 JP 2003-174784 A 20030619 (JPA, 20070816, Y)
 PRAIT JPA Patent application
 IPCI B26D0001-24 [I,A]
 IPCR B26D0007-26 [N,A]
 EPC B26D0001-24B
 ICO L26D0007:26C2
 FA AI; AN; DAV; DS; DT; EPC; ICO; IN; INS; IPC; IPCI; IPCR; LA; PA; PAS; PI;
 PIT; PRAI; TI

LEGAL STATUS

AN 24180089 INPADOCDB [Full-text](#)
 20041222 EPAK + DESIGNATED CONTRACTING STATES:
 EP A1
 AT BE BG CH CY CZ DE DK EE ES FI FR GB GR HU IE IT LI LU
 MC NL PL PT RO SE SI SK TR
 20041222 EPAX + EXTENSION OF THE EUROPEAN PATENT TO
 AL HR LT LV MK
 20050803 EP17P + REQUEST FOR EXAMINATION FILED
 20050603
 EXA Examination, Search Report
 20050914 EPAKX + PAYMENT OF DESIGNATION FEES
 DE FR GB
 20061004 EPAK + DESIGNATED CONTRACTING STATES:
 EP B1
 DE FR GB
 20061004 EPREG REFERENCE TO A NATIONAL CODE
 GBFG4D + GB: EUROPEAN PATENT GRANTED
 20061116 EPREF CORRESPONDS TO:
 DE 602004002620 P 20061116
 20070314 EPRAP2 TRANSFER OF RIGHTS OF AN EP PUBLICATION
 FUJIFILM CORPORATION
 CHG Change of Owner, Inventor, Applicant
20070315
 20070411 EPREG REFERENCE TO A NATIONAL CODE
 GB732E GB: AMENDMENTS TO THE REGISTER IN RESPECT OF CHANGES OF
 NAME OR CHANGES AFFECTING RIGHTS (SECT. 32/1977)
 CHG Change of Owner, Inventor, Applicant
20070419
 20070420 EPET + FR: TRANSLATION FILED
20070510
 20070912 EP26N + NO OPPOSITION FILED
 20070705
20070914
 20070928 EPREG REFERENCE TO A NATIONAL CODE
 FRTP FR: TRANSMISSION OF PROPERTY
 CHG Change of Owner, Inventor, Applicant
20071011

20070928 EPREG REFERENCE TO A NATIONAL CODE
FRCD FR: CHANGE OF NAME OR COMPANY NAME
CHG Change of Owner, Inventor, Applicant
.....20071011
20101130 EPPGFP + POSTGRANT: ANNUAL FEES PAID TO NATIONAL OFFICE
DE: 20100519
Payment Year: 07
.....20101202
20101130 EPPGFP + POSTGRANT: ANNUAL FEES PAID TO NATIONAL OFFICE
FR: 20100729
Payment Year: 07
.....20101202
20101130 EPPGFP + POSTGRANT: ANNUAL FEES PAID TO NATIONAL OFFICE
GB: 20100609
Payment Year: 07
.....20101202

DISPLAY FAM

PATENT FAMILY INFORMATION
AN 24180089 INPADOCDB

+-----PRAI-----+			+-----AI-----+		
JP 2003-174783	A	20030619	CN 2004-10059710	A	20040617
			DE 2004-602004002620	T	20040615
			EP 2004-13971	A	20040615
			JP 2003-174783	A	20030619
			US 2004-868808	A	20040617
JP 2003-174784	A	20030619	CN 2004-10059710	A	20040617
			DE 2004-602004002620	T	20040615
			EP 2004-13971	A	20040615
			JP 2003-174784	A	20030619
			US 2004-868808	A	20040617
+-----AI-----+			+-----PI-----+		
CN 2004-10059710	A	20040617	CN 1572446	A	20050202
DE 2004-602004002620	T	20040615	DE 602004002620	D1	20061116
EP 2004-13971	A	20040615	EP 1488896	A1	20041222
			EP 1488896	B1	20061004
JP 2003-174783	A	20030619	JP 2005007524	A	20050113
JP 2003-174784	A	20030619	JP 2005007525	A	20050113
US 2004-868808	A	20040617	US 20040255743	A1	20041223

2 priorities, 6 applications, 7 publications

DISPLAY ALL

AN 51399732 INPADOCDB UP 20070426 UW 200717
FN 34407383
TI Neck fastening for mechanical line-fastening of insulating material and sealing tracks on flat roofs consists of rail with holes and fastenings formed from screws anchored onto rail bottom and supported with head on rail.
Kehlbefestigung fuer die mechanische Linienbefestigung von Daemmmaterialien und Abdichtungsbahnen auf Flachdaechern.
TL English; German
PA HARALD ZAHN GMBH
PAS ZAHN HARALD GMBH, DE
DT Patent

INPADOCDB

PI DE 102005022624 A1 20061123
 PIT DEAL DOC. LAID OPEN (FIRST PUBLICATION)
 DAV 20061123 unexamined-printed-without-grant
 STA PRE-GRANT PUBLICATION
 AI DE 2005-102005022624 A 20050517
 AIT DEA Patent application
 PRAI DE 2005-102005022624 A 20050517 (DEA)
 PRAIT DEA Patent application
 IPCI E04D0005-14 [I,A]; E04B0001-74 [I,A]; E04D0003-36 [I,A]; E04D0005-00
 [I,C*]; E04B0001-74 [I,C*]; E04D0003-36 [I,C*]
 AB Neck fastening consists of a rail with holes made in the rail bottom and
 individual fastenings. Fastenings are each formed from a screw (1) which
 is put in the rail base, supported with its head (3) on the rail and
 which cuts with its end into the roof bottom or juts into a wall plug
 anchored into the roof base. From both sides of the hole on the rail
 narrow positioning edges or noses protrude on which the underside of the
 screw head lies. When its clamping force is held steady suspended see-saw
 like between its positioning edges or noses, the rail lies on the
 underside of the screw head.
 AL English
 AS transcript
 FA AB; AI; AN; DAV; DT; IPC; IPCI; PA; PAS; PI; PIT; PRAI; TI
 CHG TI A

DISPLAY BIB RE

AN 59518659 INPADOCDB ED 20091015 EW 200942 UP 20091022 UW 200943
 FN 38441986
 TI Verfahren zur Beschichtung eines metallischen Substrats mit einer Schicht
 aus niedrig legiertem Stahl.
 Method to coat a metallic substrate with low alloy steel layer.
 Procédé de revêtement d'un substrat métallique avec un revêtement a
 faible alliage d'acier.
 TL German; English; French
 IN CHILDS, CHRISTOPHER; MARCHANT, GEOFFREY
 INS CHILDS CHRISTOPHER, GB; MARCHANT GEOFFREY, GB
 PA SIEMENS AKTIENGESELLSCHAFT
 PAS SIEMENS AG, DE
 DT Patent
 PI EP-----2108476 A1 20091014 English
 PIT EPA1 APPLICATION PUBLISHED WITH SEARCH REPORT
 DAV 20091014 examined-printed-without-grant
 STA PRE-GRANT PUBLICATION
 DS R: AT BE BG CH CY CZ DE DK EE ES FI FR GB GR HR HU IE IS IT LI
 LT LU LV MC MT NL NO PL PT RO SE SI SK TR
 XS R: AL BA MK RS
 AI 2008EP-000007060 A 20080409
 AIT EPA Patent application
 PRAI 2008EP-000007060 A 20080409 (EPA, 20091015, Y)
 PRAIT EPA Patent application
 REC 6. THERE ARE 6 CITED REFERENCES (5 PATENT, 1 NON PATENT) AVAILABLE FOR
 THIS RECORD. ALL CITATIONS ARE AVAILABLE IN THE RE FORMAT.
 REP EP 1835189 A2 (SEA, pat, Cat: X) GEN ELECTRIC, US
 EP 1898048 A1 (SEA, pat, Cat: A) HITACHI LTD, JP
 WO 2006111520 A1 (SEA, pat, Cat: A) SIEMENS AG, DE; SHEPHERD
 ANDREW, GB; WALKER PAUL
 METHREW, GB
 US 4300474 A (SEA, pat, Cat: AD) ROLLS ROYCE
 GB 2052566 A (APP, pat) ROLLS ROYCE
 REXP XP008053341 (SEA, Cat: Y)

REN (1) NOWOTNY S: "BESCHICHTEN, REPARIEREN UND GENERIEREN DURCH
PRAEZISIONS-AUFTRAGSCHWEISSEN MIT LASERSTRAHLEN//CLADDING, REPAIR, AND
FREEFORMING BY BUILD-UP WELDING USING LASER IRRADIATION" VAKUUM IN
FORSCHUNG UND PRAXIS, WILEY-VCH, WEINHEIM, DE, vol. 14, no. 1, 1 February
2002 (2002-02-01), pages 33-37, XP008053341 ISSN: 0947-076X (SEA, Cat: Y)
REC 6. THERE ARE 6 CITED REFERENCES (5 PATENT, 1 NON PATENT) AVAILABLE FOR
THIS RECORD.

In North America

CAS
STN North America
P.O. Box 3012
Columbus, Ohio 43210-0012 U.S.A.

CAS Customer Center:
Phone: 800-753-4227 (North America)
614-447-3700 (worldwide)
Fax: 614-447-3751
E-mail: help@cas.org
Internet: www.cas.org

In Europe

FIZ Karlsruhe
STN Europe
P.O. Box 2465
76012 Karlsruhe
Germany
Phone: +49-7247-808-555
Fax: +49-7247-808-259
E-mail: helpdesk@fiz-karlsruhe.de
Internet: www.stn-international.com

In Japan

JAIICI (Japan Association for
International Chemical Information)
STN Japan
Nakai Building
6-25-4 Honkomagome, Bunkyo-ku
Tokyo 113-0021, Japan
Phone: +81-3-5978-3601 (Technical Service)
+81-3-5978-3621 (Customer Service)
Fax: +81-3-5978-3600
E-mail: support@jaici.or.jp (Technical Service)
customer@jaici.or.jp (Customer Service)
Internet: www.jaici.or.jp