

KOREAPAT (Korean Patent Abstracts)

Subject Coverage	All areas of science and technology, i.e., all classes of the International Patent Classification					
File Type	Bibliographic					
Features	Thesaurus	International Patent Classification (/IPC)				
	Alerts (SDIs)	Weekly				
	CAS Registry Numbers®	<input type="checkbox"/>	Page Images	<input type="checkbox"/>	STN AnaVist	<input type="checkbox"/>
	Keep & Share	<input checked="" type="checkbox"/>	SLART	<input checked="" type="checkbox"/>	STN Easy	<input checked="" type="checkbox"/>
	Learning Database	<input type="checkbox"/>	Structures	<input type="checkbox"/>	STN Viewer	<input type="checkbox"/>
Record Content	<ul style="list-style-type: none"> • Inventor and assignee data, publication information, titles and abstracts, and IPC codes • An image of a representative drawing is also included 					
File Size	More than 1.3 million records, more than 1.2 million images (04/11)					
Coverage	1979-present; A-documents from 2000 onwards; B-documents from 1979 to present					
Updates	Monthly with about 25,000 records					
Language	English					
Database Producer	Korean Institute of Patent Information (KIPI) 6-8 th Fl. KIPS 647-9 Yeoksam-dong Gangnam-ku, Seoul 135-980 Korea Phone: +82 2 3452 8144 Fax: +82 2 3453 5951 Copyright Holder					
Database Supplier	FIZ Karlsruhe STN Europe P.O. Box 2465 76012 Karlsruhe Germany Phone: +49-7247-808-555 Fax: +49-7247-808-259 E-mail: helpdesk@fiz-karlsruhe.de					

Sources

Korean Patent Abstracts (CD-ROM), Examined and Unexamined Patents

User Aids

- Online Helps (HELP DIRECTORY lists all help messages available)
 - STNGUIDE
-

Clusters

- ALLBIB
 - AUTHORS
 - CORPSOURCE
 - HPATENTS
 - PATENTS
- [STN Database Clusters](#) information (PDF).
-

Pricing

See the [STN Price List](#) or enter HELP COST at an arrow prompt.

Search and Display Field Codes

Fields that allow left truncation are indicated by an asterisk (*).

General Search Fields

Search Field Name	Search Code	Search Examples	Display Codes
Basic Index* (contains single words from title (TI), and abstract (AB) fields)	None or /BI	S ?PHENYLETHER? S FLUID AND EMULS?	TI, AB
Abstract	/AB	S LASER/AB	AB
Accession Number	/AN	S 2004:000001/AN	AN
Application Country (WIPO code and text)	/AC	S KR/AC AND L1	AI
Application Date (1)	/AD	S JUL-SEP 1995/AD	AI
Application Number (2,3)	/AP	S KR2000-10007/AP S KR1020000000007/AP	AI
Application Number, Original	/APO	S KR1020047001082/APO	APO
Application Year (1)	/AY	S 1999-2000/AY	AI
Document Type (code and text)	/DT	S P/DT	DT
Entry Date (1)	(or /TC) /ED	S PATENT/DT S ED=AUG 2004	ED
Field Availability	(or /UP) /FA	S GI/FA	FA
Graphic Image Size (1)	/GIS	S GIS<=350	GIS
Graphic Image Type	/GIT	S TIF/GIT	GIT
International Patent Classification (contains ICM and ICS)	/IC	S A24B/IC	IC
Inventor	/IN (or /AU)	S MANDEL?/IN S SATO AKIHIRO/IN	IN
IPC (contains ICM, ICS, IPCI, IPCR) (4)	/IPC	S A01B0001-02/IPC S H05B0006-36+NT/IPC	ICM, ICS, IPCI, IPCR
IPC Subgroup Subgroup Range Searchable, Version 1-7 (1)	/SGR	S C01B/ICM (S) 100-2000/SGR	ICM, ICS
IPC, Action Date (1)	/IPC.ACD	S IPC.ACD=JAN 2006	IPC.TAB
IPC, Keyword Terms	/IPC.KW	S CORE/IPC.KW	IPC.TAB
IPC, Main	/ICM	S A01N001/ICM S A01B059-06/ICM	ICM, IC
IPC, Secondary	/ICS	S A01G023/ICS	ICS, IC
IPC, Version	/IPC.VER	S 200601/IPC.VER	IPC.TAB
Main Group of IPC Version 1-7 Range Searchable (1)	/MGR	S 10-20/MGR (S) C07C/IC	ICM, ICS
Patent Assignee (5)	/PA (or /CS)	S HITACHI/PA S NIPPON CHEM?/PA	PA
Patent Country (WIPO code and text)	/PC	S KR/PC	PI
Patent Kind Code	/PK	S KRA/PK	PI
Patent Number (2,3)	/PN (or /PATS)	S KR200027/PN S KR-----200027/PN	PI, PNO
Patent Number, Original	/PNO	S KR100118011/PNO	PNO
Priority Country (WIPO code and text)	/PRC	S US/PRC S UNITED STATES/PRC	PRAI
Priority Date (1)	/PRD	S JAN-APR 2004/PRD	PRAI
Priority Number (2,3)	/PRN	S AT1985-2561/PRN	PRAI, PRNO
Priority Number, Original	/PRNO	S UK48367/PRNO	PRNO
Priority Type	/PRT	S INTERNATIONAL APPLICATION/PRT	not displayed
Priority Year (1)	/PRY	S PRY=2003	PRAI
Publication Date (1)	/PD	S PD=FEB 1999	PI
Publication Year (1)	/PY	S KRA?/PK (S) 2004/PY	PI
Title	/TI	S SUPPLYING OXYGEN?/TI	TI
Title Language (ISO code and text)	/TL	S ENGLISH/TL S EN/TL	TL

KOREAPAT

- (1) Numeric search field that may be searched using numeric operators or ranges.
- (2) Application, priority, and patent numbers are available in Derwent and STN format. STN is the default. Enter SET PAT DERWENT to change to the Derwent format. To return to the STN format, enter SET PAT STN.
- (3) Field contains numbers also in original input format.
- (4) An online thesaurus is available in this field.
- (5) Search with implied (S) proximity is available in this field.

Super Search Fields (1)

Search Field Name	Search Code	Fields Searched	Search Examples	Display Codes
Application Number Group	/APPS	/AP, /PRN	S KR2000-1001/APPS	AI, PRAI

- (1) Enter a super search code to execute a search in one or more fields that may contain the desired information. Super search fields facilitate crossfile and multifile searching. EXPAND may not be used with super search fields. Use EXPAND with the individual field codes instead.

International Patent Classification (/IPC) Thesaurus

The classifications, validity and catchwords for the main headings and subheadings from the current (8th) edition of the WIPO International Patent Classification (IPC) manual are available. The classifications from the previous editions (1-7) are also available as separate thesauri. To EXPAND and SEARCH in the thesauri for editions 1-7, use the field code followed by the edition number, e.g., /IPC2, for the 2nd edition. Catchwords are included only in the thesauri for the 8th, 7th, 6th, and 5th editions.

Code	Content	Examples
ADVANCED (ADV)	Advanced Codes for the Core Level IPC Code	E A61K0006-02+ADVANCED/IPC
ALL	All Associated Terms (BT, SELF, NT, RT)	E C01C003-00+ALL/IPC
BRO (MAN)	Complete Class	E C01C+BRO/IPC
BT	Broader Term (BT, SELF)	E C01F001-00+BT/IPC
CORE (COR)	Core Codes for the Advanced Level IPC Code	E G08C0019-22+CORE/IPC
ED	Complete title of the SELF term and IPC manual edition	E C01F001-00+ED/IPC
HIE	Hierarchy Term (Broader and Narrower Term) (BT, SELF, NT)	E C011003-00+HIE/IPC
INDEX	Complete title of the SELF term	E C01F001-00+INDEX/IPC
KT	Keyword Term (catchwords) (SELF, KT)	E CYANOGEN+KT/IPC
NEXT	Next Classification	E C01C001-00+NEXT5/IPC
NT	Narrower Terms (SELF, NT)	E C01C+NT/IPC
PREV	Previous Classification	E C01C001-12+PREV10/IPC
RT (SIB)	Related Terms (SELF, RT)	E C01C003-20+RT/IPC
TI	Complete Title of the SELF Term and Broader Terms (BT, SELF)	E C01F001-00+TI/IPC

DISPLAY and PRINT Formats

Any combination of formats may be used to display or print answers. Multiple codes must be separated by spaces or commas, e.g., D L1 1-5 TI PI. The fields are displayed or printed in the order requested.

Hit-term highlighting is available for all fields. Highlighting must be ON during SEARCH to use the HIT, KWIC, and OCC formats.

Format	Content	Examples
AB AI (AP) (1) AN APO (2) APPS DT (TC) ED (UP) FA (2) GI (3) GIS GIT (2) IC ICM ICS IN (AU) IPCI IPCR PA (CS) PI (PN, PATS) (1) PIT PK PNO (2) PRAI (PRN) (1) PRNO (2) TI	Abstract Application Information Accession Number Application Number, Original Application Number Group Document Type Entry Date Field Availability Graphic Image Graphic Image Size Graphic Image Type International Patent Classification (ICM, ICS) IPC, Main IPC, Secondary Inventor IPC, Initial IPC, Reclassified Patent Assignee Patent Information Patent Information Publication Type Patent Kind Code Patent Number Original Priority Information Priority Number Original Title (contains Title Language)	D TI AB 1-5 D AI D L3 AN D APO D APPS D DT D ED D FA D GI D GIS D GIT D IC D ICM D ICD D IN D IPCI D IPCR D PA D PI D PIT D PK D PNO D PRAI D PRNO D TI
ABS ALL (MAX) (1) ALLG (1,3) DALL (1) IALL (IMAX) (1) IALLG (1,3) BIB (1) IBIB (1) IPC IPC.TAB MAX.G (1,3) SAMPLE (SAM, TRIAL, TRI, FREE) SCAN (4) STD (1) ISTD (1)	AN, AB AN, ED, TI, IN, PA, PIT, PI, AI, PRAI, IPC, AB AN, ED, TI, IN, PA, PIT, PI, AI, PRAI, IPC, GI, AB ALL, delimited for post processing ALL, indented with text labels ALLG, indented with text labels AN, ED, TI, IN, PA, PIT, PI, AI, PRAI BIB, indented with text labels ICM, ICS, IPCI, IPCR IPC, IPC.ACD, IPC.KW, IPC.VER in tabular format AN, ED, TI, IN, PA, PIT, PI, AI, PRAI, IPC, GIS, GI, AB AN, TI, IPC TI (random display without answer numbers) AN, ED, TI, IN, PA, PIT, PI, AI, PRAI, IPC STD, indented with text labels	D ABS D ALL D ALLG D DALL D IALL 1-3 D IALLG D BIB D IBIB D IPC D IPC.TAB D MAXG D SCAN D STD D ISTD
HIT KWIC OCC	Hit term(s) and field(s) Up to 50 words before and after hit term(s) (KeyWord-In-Context) Number of occurrences of hit term(s) and field(s) in which they occur	D HIT D KWIC D OCC

- (1) By default, patent numbers, application and priority numbers are displayed in STN Format. To display them in Derwent format, enter SET PATENT DERWENT at an arrow prompt. To reset display to STN Format, enter SET PATENT STN.
- (2) Custom display only.
- (3) Any program that handles TIFF and JPEG images compressed in Group 4 fax format, e.g., STN Express, may be used to capture graphic images from DISPLAY, or they may be viewed directly on the screen during an STN[®] on the WebSM session.
- (4) SCAN must be specified on the command line, i.e., D SCAN or DISPLAY SCAN.

KOREAPAT**SELECT, ANALYZE, and SORT Fields**

The SELECT command is used to create E-numbers containing terms taken from the specified field in an answer set.

The ANALYZE command is used to create an L-number containing terms taken from the specified field in an answer set.

The SORT command is used to rearrange the search results in either alphabetic or numeric order of the specified field(s).

Field Name	Field Code	ANALYZE/ SELECT (1)	SORT
Abstract	AB	Y	Y
Accession Number	AN	Y	Y
Application Country	AC	Y	N
Application Date	AD	Y	N
Application Number	AP (AI)	Y (2)	Y
Application Number Group	APPS	Y (2)	Y
Application Number Original	APO	Y	Y
Application Year	AY	Y	N
Document Type	DT (TC)	Y	Y
Entry Date	ED	Y	Y
Field Availability	FA	Y	N
Graphic Image Size	GIS	Y	N
Graphic Image Type	GIT	Y	Y
International Patent Classification	IC	Y	N
Inventor	IN (AU)	Y	Y
IPC (ICM, ICS, ICA, ICI, IPCI, IPCR)	IPC	Y (3)	Y
IPC, Advanced Level Symbols	IPC.A	Y (3)	N
IPC, Advanced Level Symbols for Invention	IPC.AI	Y (3)	N
IPC, Core Level Symbols	IPC.C	Y (3)	N
IPC, Core Level Symbols for Invention	IPC.CI	Y (3)	N
IPC, Initial	IPCI	Y (3)	N
IPC, Main	ICM	Y	Y
IPC, Reclassified	IPCR	Y (3)	N
IPC, Secondary	ICS	Y	Y
Patent Assignee	PA (CS)	Y	Y
Patent Country	PC	Y	Y
Patent Kind Code	PK	Y	Y
Patent Number	PN (PATS, PI)	Y (2)	Y
Patent Number Original	PNO	Y	N
Pre-IPC8 Symbols from the ICM and first IPC8 values from 2006 onwards	IPC.F	Y (3)	N
Priority Country	PRC	Y	Y
Priority Date	PRD	Y	Y
Priority Number	PRN (PRAI)	Y (2)	Y
Priority Number Original	PRNO	Y	N
Priority Type	PRT	Y	N
Priority Year	PRY	Y	Y
Publication Date	PD	Y	Y
Publication Year	PY	Y	Y
Title	TI	Y (default)	Y
Title Language	TL	Y	Y

(1) HIT may be used to restrict terms extracted to terms that match the search expression used to create the answer set, e.g., SEL HIT TI.

(2) SELECTed and SORTed application, priority and patent numbers are in the format set by the Messenger SET PATENT command, either DERWENT or STN.

(3) Appends /IPC to the terms created by SELECT.

Sample Records

DISPLAY ISTD

AN 2007:106679 KOREAPAT ED 20080107
 TI SENSOR APPARATUS, CAPABLE OF ELIMINATING THE BONDING PROCESS OF A SENSOR MODULE BY INTEGRALLY FORMING THE SENSOR MODULE WITH A CONNECTOR CONNECTION SECTION BY AN INSULATING RESIN
 TL English
 IN SHINJO IZURU
 PA MITSUBISHI ELECTRIC CORPORATION
 PIT KRA Unexamined Patent Application
 PI KR 2007104194 A 20071025
 AI KR 2006-88467 20060913
 PRAI JP 2006-116878 20060420
 IPCI G01L0009-00 [I,A]; G01L0019-00 [I,A]; H01L0029-84 [I,A]; G01L0009-00 [I,C*]; G01L0019-00 [I,C*]; H01L0029-66 [I,C*]

DISPLAY MAXG

AN 2004:017120 KOREAPAT ED 20040819
 TI INTEGRATED DEVELOPER OF WET COLOR LASER PRINTER
 TL English
 IN SHIN, HYEON SEONG
 PA SAMSUNG ELECTRONICS CO., LTD.
 PIT KRA Unexamined Patent Application
 PI KR--2004024813 A 20040322
 AI 2002KR-0056262 20020916
 PRAI 2002KR-0056262 * 20020916

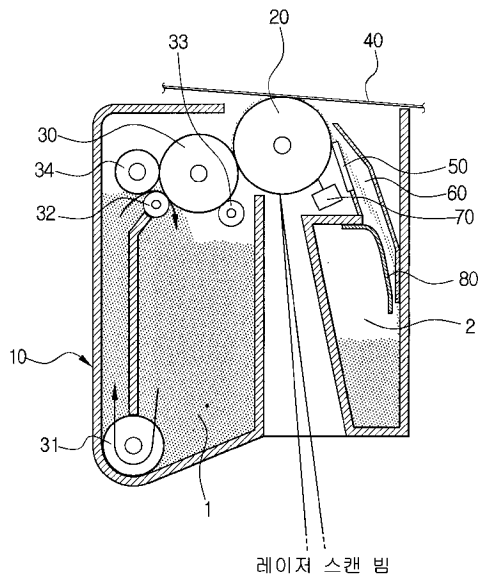

IC
 ICM G03G015-10
 GIS 17524
 AB PURPOSE: An integrated developer of a wet color laser printer is provided to cut off a waste developer storage entrance so that a waste developer stored in a waste developer storage does not flow back through the entrance, thereby preventing the waste developer from flowing out.
 CONSTITUTION: A photosensitive drum(20) has an electric charge layer, and

KOREAPAT

forms a predetermined electrostatic latent image. A developing roller(30) moves a developer to the photosensitive drum(20) to develop the electrostatic latent image as a visual image. An upper end of a cleaning blade(50) is contacted with the photosensitive drum(20) to remove a remaining waste developer. A developing cartridge(10) receives the photosensitive drum(20), the developing roller(30), and the cleaning blade(50). The developing cartridge(10) is divided into a developer storage(1) and a waste developer storage(2). The developer storage(1) stores the developer. The waste developer storage(2) stores the waste developer removed by the cleaning blade(50). A leakage prevention member(80) cuts off an entrance of the waste developer storage(2) so that the waste developer does not flow back through the entrance. .COPYRGT. KIPO 2004

DISPLAY ALL

AN 2007:100314 KOREAPAT ED 20080107
 TI LITHIUM SECONDARY BATTERY EMPLOYING EXTERNAL COVER PROVIDED WITH RIB INSIDE AT BOTH SIDES OF CORE PACK
 TL English
 IN KWAG, NO HYUN; SEO, KYUNG WON; LEE, SANG JOO
 PA SAMSUNG SDI CO., LTD.
 PIT KRBl Examined Patent Application second publication; since 970930 granted patent
 PI KR-----770106 B1 20071018
 AI 2006KR-0103371 20061024
 PRAI 2006KR-0103371 * 20061024
 IPCI H01M-0010-04 [I,A]; H01M-0002-10 [I,A]; H01M-0002-08 [I,A]; H01-M0010-04 [I,C*]; H01M-0002-10 [I,C*]; H01M-0002-08 [I,C*]
 AB PURPOSE: A lithium secondary battery is provided to block the channel of a resin to an external cover side in case of the resin molding of a core pack upper region, thereby reducing the percent defective of an external cover due to the flow of a resin.
 CONSTITUTION: A lithium secondary battery comprises a core pack which comprises a bare cell, and a protection circuit module arranged on the upper surface of the bare cell so as to be connected electrically with the bare cell through a lead plate; an external cover(320) which covers the both end sides of the core pack where the lead plate is arranged; and a resin molding part which is formed at the upper part of the core pack and comprises some part of the external cover and the protection circuit module, wherein a rib(326) is formed at the inside of the external cover to isolate the gap generated between the both end sides of the external cover and the core pack from the resin molding part by the lead plate.
 .COPYRGT. KIPO 2007

In North America

CAS
 STN North America
 P.O. Box 3012
 Columbus, Ohio 43210-0012 U.S.A.

CAS Customer Center:
 Phone: 800-753-4227 (North America)
 614-447-3700 (worldwide)
 Fax: 614-447-3751
 E-mail: help@cas.org
 Internet: www.cas.org

In Europe

FIZ Karlsruhe
 STN Europe
 P.O. Box 2465
 76012 Karlsruhe
 Germany
 Phone: +49-7247-808-555
 Fax: +49-7247-808-259
 E-mail: helpdesk@fiz-karlsruhe.de
 Internet: www.stn-international.com

In Japan

JAICI (Japan Association for
 International Chemical Information)
 STN Japan
 Nakai Building
 6-25-4 Honkomagome, Bunkyo-ku
 Tokyo 113-0021, Japan
 Phone: +81-3-5978-3601 (Technical Service)
 +81-3-5978-3621 (Customer Service)
 Fax: +81-3-5978-3600
 E-mail: support@jaici.or.jp (Technical Service)
 customer@jaici.or.jp (Customer Service)
 Internet: www.jaici.or.jp